

Musical Variants in Digital Practice

Eleanor Selfridge-Field

6/2/2008; rev. 7/3/2008

What is a variant? The word variant conjures up associations with several different phenomena. At the most general level (1), a piece of music which intentionally quotes material from another piece may be considered, with respect to this shared core, a variant, although it is usually considered a derivative and enjoys as its primary identity that of an independent composition. (2) Substitute material (often a whole movement, sometimes the resetting of an entire vocal or instrumental part) constitutes another hypothetical species of the variant material. Here the context is shared by what are usually considered two related works. (3) The ordinary run of variants that are encountered in editing music are generally more limited in scope and may amount to only a few notes here and there, the existence of versions for somewhat different performing resources or involving a change of key. (4) Non-ordinary variants are those which involve some kind of difference which is unusual in its nature or extent. Our focus here is on minor, ordinary variants (3) and major, extensive variants (4) in the context of digital philology.

Quite apart from the variety of phenomena to which the word “variant” is applied, the possibilities for constructing a typology of variants are also very numerous. In practice, files containing musical data are usually tailored to a particular use. They are constrained by the representation system in which they are embedded. They may be constrained or enhanced by data structures, which are often optimized for specific software, rather than for a specific musical goal. The encoding of complete scores usually aims at one of four goals:

- (a) The creation of a specifically visual instantiation of a musical work.
- (b) The production of material suitable for electronic output of sound (MIDI).
- (c) The creation of an authoritative source for reference.
- (d) The preservation of a series of digital images.¹

These goals—which related to the professions of publishing, performance, musicology, and librarianship—necessarily influence one’s approach to the handling of variants, and therefore the typology of variants that is most congenial to the goal.

¹ Digital preservation does not require any machine understanding of the content. It only stores information about pixels in a digital image.

Our goal at the Center for Computer Assisted Research in the Humanities has been to create an archive of encodings of complete scores which can support screen-viewing (a), sound output (b), and a basis for making new editions, authoritative (c) or not. We do not attempt preservation-quality archiving of digital images (d) unless we work from materials that are otherwise rare. The *MuseData* databases² are conceived for multiple practical uses. The most important are to provide a secure basis for such activities as future editions (musicology), musical analysis (music theory), classroom use (music pedagogy), and data conversion (extensible uses of one data set). Being intended for the support of applications in notation, sound, and analysis, the *MuseData* encoding scheme is more articulate in pitch and more practical in its rhythmic scheme than MIDI. It supports notation directly, which the Humdrum encoding scheme (optimized for analysis) does not.

We handle minor variants within the context of a single file when only random notes require a correction to pitch or duration. In this case, the typology that works best is a functional (end-use) typology. What is surprising, however, is how many varieties of minor variants we encounter in the scope of a repertory that is limited to about 200 years of musical history (c. 1700-1900). These are discussed in the first category, functional typologies, because we design solutions based on what use we expect users to make of the data.

Major variants necessarily require multiple encodings of the effected portion of the work—one movement, one voice, or one instrument. Since some of our encodings are of complete operas and oratorios, multiple movements may require special treatment. In some cases we encoded multiple early sources for the purpose of exploring the degree to which a “work” differs between or among them. Ideally, the deductive exploration of variants could be instructive for later editors and software developers. In these cases it is most useful to categorize variants hierarchically, that is, according to the extent of the work they affect.

Because we frequently begin with out-of-copyright editions, we frequently encounter notational styles which are obsolescent. If we “encode the source,” we retain some of these obsolescent features (clef signs, ornaments, et al). Examples will be found below. If we encode from a new edition, then of course a modern style is used. Quite often, we retain the obsolete features in the original encoding but make a spin-off modernized edition. The PDFs of J. S. Bach’s Well-Tempered Clavier as well as Haydn’s last twelve and Beethoven first three symphonies on our website

² These databases contain fully encoded scores of music by Corelli (72 works), J. S. Bach (520), Handel (102), Telemann (70), Vivaldi (97), Haydn (77), Mozart (62), Beethoven (33), Schubert (15), and Brahms (1).

(<http://www.musedata.org/>) are “modernized” to facilitate playability.³ The greatest degree of change occurs in one of the most familiar repertoires—Bach’s four-part chorale harmonizations. A century ago, readers of the Bach Gesellschaft edition could be expected to sight-read the SATB (soprano, alto, tenor, and bass) C-clefs with ease. Today (at least in the US) they are most comfortable with the four voices shown on two staves (G- and F-clefs) and without text underlay.⁴ Created from our original encoding a compromise version of the 185 BG chorales, retaining the text underlay and the four-clef arranging but modernizing the clef signs and pitch notation (Figure 1).

Figure 1. Chorale No. 25, “Christ lag in Todesbanden,” in the MuseData adaptation of the Bach Gesellschaft version.

The main aim of CCARH has always focused on (c), the creation of authoritative reference material which may form the basis of future editions of multiple kinds. In our case, this has been pursued through the encodings themselves, whereas in projects of more recent origin, such as that of the C. M. von Weber edition, it has been focused on coordinating graphical views of multiple sources for the same work. The first is costly in encoding time and verification of data; the second is expensive in terms of storage space. Only a generation from now will we truly know which one is more durable. ASCII encodings (of which CCARH’s *MuseData* corpora all consist) seem to

³ The PDFs found at <http://www.musedata.org> are made not from scanned images but from newly printed material generated from the stored “Stage 2” data at the same website. Those in search of images which actually correspond to processable data will find it here.

⁴ Part of the confusion among US students comes about from their greater familiarity with the Riemenschneider collection of chorale harmonizations, which contains not only the 185 works provided by the Gesellschaft but also the chorale harmonizations collected by Bach’s followers after his death.

survive the seemingly infinite number of changes of operating system that commercial vendors inflict on scholars. Methods for data interchange and graphical interfaces change fairly often.

1. *Functional and end-use typologies in MuseData*

In early experiments with multiple uses of MuseData encodings, we encountered many situations in which what is best for notation is inappropriate for sound, or vice versa. Some instances include works with ornamentation or with transposing instruments. For ornamentation, one wants a mere symbol for a score but a series of notes for a playback. Hewlett came up with the idea of embedding in the encoded material what he calls “sound suggestions” and “print suggestions.” (Both concepts were subsequently inscribed in MusicXML). We soon found ourselves producing variant encodings to facilitate one or another end use of material from singular sources. Although this is not a standard context for the use of the word “variant”, it seems inevitable that the digital world will require differentiation of materials according to their intended purpose.

a. Sound suggestions

Sound suggestions are single records added to MuseData encodings to suggest points at which tempo or dynamics changes may enhance playback via MIDI. The records can become quite elaborate when they indicate the possible realization of an ornament in a MIDI playback.⁵ MIDI files are cloyingly stuck in a metronomic rut unless such editorial refinements are introduced. The ear tires very quickly of their lack of expressive features, but since ideas of dynamics and tempo are generally considered the province of performers, one does not want to confer a one-size-fits-all interpretation on entire works. Sound suggestions offer a middle ground of possible interpretation to those who do not want to hand-edit MIDI files or are not yet experienced in adding nuances.

A more complicated usage of sound suggestions is to provide the realization of ornaments in Baroque music. Passages for violin and for solo harpsichord sound barren without the realization of ornaments. Here, sound suggestions can address the middle ground: the user may use them (without software equipped the interpret them) or ignore them. In Figure 2 we see sound suggestions (highlighted) in the flute part for the second movement (Andante) of the Second Brandenburg Concerto.

```
measure 5
rest    4      q
rest    4      q
```

⁵ The same indications could be used in any symbol-based context designed to generate sound output, such as CSound. To our knowledge, no such implementations have been made.

```

A5      4      q      d
measure 6
Bf5     6      q.     d
A5      2      e      d
G5      1      s      d [[ (
Bf5     1      s      d [=]
A5      2      e      d ] )
measure 7
F5      4      q      d      t
S C33:uwn8s14t50
E5      2      e      d [ (
D5      2      e      d ] )
A5      4      q      d
measure 8
B5      6      q.n   d      (
C6      1      s      d [[ (
D6      1      s      d ]] )
C6      1      s      d [[ (
B5      1      s      d [=]
C6      2      e      d ] )
measure 9
G#5     4      q #   d      t
S C33:uhn8s14t50
F#5     2      e #   d [ (
E5      2      e      d ] )
C6      4      q      d

```

Figure 2. Sound suggestions (highlighted) in the flute part for the second movement (Andante) of the Second Brandenburg Concert. (The flute rests in the first four bars.)

Another feature of the MuseData encoding system addresses the discrepancy between what is literally written and what should be understood in a “sound” interpretation of a MIDI file. A recurrent area of attention is the dotted note. In the case of French double-dotting, the widely subscribed view is that in the “French overture” style, the single dot was really a double dot and the complementary sixteenth note which followed was really a 32nd. A well known example occurs in the D-Major Prelude of Book One of the *Well-Tempered Clavier* (Figure 3).



Figure 3. J. S. Bach: Fugue in D Major from Book I of the Well-Tempered Clavier (1722).

In a sense, accommodation of such discrepancies offers a way of dealing with a certain kind of musical variant. Examples are particularly prevalent when editions of different eras are compared, for “common Western notation” has continually evolved and has always varied somewhat from publisher to publisher.

In the music of Handel, it is also not uncommon for double-dotting to be given in one part, while single-dotting is given in another. Debates have raged for years over Handel’s “intentions”. Were discrepant values to be synchronized in performance? Did the resolution depend on the specific

instrumentation (score and part, violin as opposed to accompanying keyboard, and vocal as opposed to instrumental parts)? There is scope to argue in many directions. One value of encoded material is that different hypotheses can be tested with sound output (as they can in resolving diverse notions of ratios between sections in duple and triple meter in music of the Renaissance).

b. Print suggestions

Print suggestions, given in records which can be ignored in notation software, indicate how best to lay out a piece of music on the page. Computers do not know how to find the inflection points most suitable for system and page breaks. Much of the labor in producing high-quality editions from garden-variety notation software packages can lie in adjusting the position of such breaks. Performers, for example, do ever want to find last bar of a movement on a new page. Notation software allocates horizontal space from the start of a movement. It has no “eye” to notice the approach of an ending. Print suggestions tell savvy software programs where they might want to space the score horizontally to avoid unwieldy breaks. The grammar and format are similar to those for sound suggestions.

c. MIDI-One and MIDI-Plus

Since MIDI is the most widely used music format in the realm of symbolic data, we carried this scheme for functional differentiation one step further by translating the data into parallel sets of MIDI files. MIDI-One is largely the standard product adapted for more pleasurable listening by modulations of tempo and dynamics but also by the realization of ornaments (from sound suggestions) and so forth. MIDI-Plus is a derivative format enhanced by articulate pitch information (since that is available in the MuseData from which it is generated), quantized to produce barlines correctly in regularly metered music, and otherwise suited to printing. Both versions are available at our download site (musedata.org).

d. Other end-uses of MuseData in translation

The principal formats we support by direct translation from MuseData are (1a) MIDI-One, (1b) MIDI-Plus, (2) **kern (for analysis with the Humdrum Toolkit), (3) SCORE (for further editing in a professional-level notation program), and (4) PDF for immediate consultation and use in performance. For any given work, the data in all these formats at <http://www.musedata.org> is in

agreement on accidentals, instrumentation, etc., since all the formats come from a single electronic source file.⁶

In recent years, an explosion in the uses of Kern code encouraged Craig Stuart Sapp, a researcher at CCARH and CHARM (UK), to set up the KernScores websites (<http://kern.ccarh.org>). The KernScores repertory represents a conflation of translations from *MuseData* encodings with works from other periods newly acquired via optical recognition, then converted on-the-fly into a dozen or more additional file formats.⁷ KernScores provides automatic translations into the open-source Guido music notation format (*.gmn), MusicXML (*.xml), piano-roll graphics in two modes (one showing pitch height, the other metric weight of each event), and harmonic-root analysis with or without Roman-numeral labeling as well as formats congenial to use for research software for a range of special purposes in cognitive and analytic studies.

2. The Encoding of Variants

In digital philology, all of the issues associated with conventional editing are present but they mingle with several others specific to digital technology. If there an obvious error in the underlying source, should it be corrected or only annotated? Is the presentation of the original material suited to the software available for intended output? Although it is generally true that, once encoded, music can be re-edited for other purposes, if the intended use changes, it may be necessary to re-encode it, particularly if some aspect of the music not originally indicated is required for the new application. A part-by-part encoding generally allows greater flexibility for later use than a score encoding. In the case of the Bach chorales, for example, it is easier to make a two-stave version of the four-part chorales from parts than to extract the four voices from a score. Such practical issues also influence the handling of variants in large-scale encoding projects. Sometimes the first choice is the most efficient, but it is the second choice that saves the drudgery of extensive hand correction.

Schemes which do not afford the possibility of replicating ambiguities in the underlying score force encoders, as first interpreters, to render some decision. A ubiquitous need for encoding ambiguity as such occurs in eighteenth-century manuscripts. Handel manuscripts are filled with slurs that have a clear initiation point (coincident with a specific event) but a vague termination point. Our data specialists study the source for clues to the interpretation. Handel's manuscripts are notoriously

⁶ Users who “mix and match” instantiations of “the same work” from different sources court the likelihood of myriad inconsistencies and lapses in content.

⁷ *MuseData* files (although not free of errors in content or encoding) are proofread many times before they are posted. KernScores are proofread once via MIDI but notated conversions are not proofread.

full of contradictions to any rule of visual grammar, however, and the more sources one consults, the less clear a resolution may be. We must assume that serious editors will consult the underlying sources for themselves. We must also hope that editors working from encoded material will develop the habit of looking in the file for notes about such interpretations.

Although the examples presented here all come from repertoires encoded in MuseData, instances in which something exact is required in an encoding where something approximate is usual in notation occur in every historical period of music history. If our subject were music of the Renaissance, then the practice of *musica ficta* would generate the need to distinguish between written accidentals as they were customarily used at the time and those assumed in performance but rarely written. A great deal of monophonic music of the Middle Ages has been encoded, invariably without rhythmic values but sometimes with indications of the neume types from which the pitches have been inferred. The generation of sound output from inspecific rhythmic information is all but impossible (at least in MIDI). Quantized output of Gregorian chant in inform note-values is hardly representative of any human practice of the past. Myriad problems of sound output exist for the more grandiose of nineteenth-century repertoires. Leaving aside the deficiencies of arbitrary meters and simulated timbres for most of the classical music studied today, we see from all of our experiences with encoding standard repertory into symbolic formats that “common Western notation” is far from systematic or complete. It is the product of centuries of interaction between those who compose, those who perform, and those who transcribe.

3. A Hierarchical Typology for Variants

One practical way to classify variant types is to consider what level of the score they affect and the degree to which they affect it. Here we organize categories of this quantitative approach into five categories: (a) note level, (b) note-group level, (c) phrase-level, (d) part-level, and (5) tree-structure variants. The first three may often concern choices in how to interpret particular symbols or passages, while the last two are usually focused on genuine differences in content.

1. Note-level variants

When one tries to straddle the sound/notation divide, the problem of one-to-many relations can come about in several ways. The case most familiar to us is that of ornaments in Baroque music. A single sign in notated music usually calls for a series of notes in actual performance (see '1a). The substitution of a single long note for a Beethoven trill or a Mozart turn can render unmediated sound output quite foreign to a piano sonata. Yet the presence of a series of notes of very short values in a score can be confusing to performers accustomed to the shorthand of a trill or turn sign. It is

completely inscrutable to software lacking the ability to identify groups of notes in MIDI input as matching the note-pattern represented in notation by one shorthand symbol. Basso continuo figuration can also present similar divergence between symbol (often giving incomplete information, sometimes giving wrong information) and the harmonic realization which could make a sound file seem more complete. Such divergences according to intended use both pose one-to-many problems. In both cases the exact number of notes to be added to produce a sound realization may be variable. How many notes must there be in a full-measure trill? How many tones should sound above the continuo? Ultimately the number varies according to the will of the performer. Duplicate files with implemented sound or print suggestions can solve all of these problems, but most commercial systems do not make provision for them.

Rhythmic interpretation proves to be a more frequent cause of encoding quandaries than pitch. The role of choices made at the time of encoding is well illustrated by our first encoding of the D-Major prelude of Book One of the Well-Tempered Clavier (music shown in Figure 2). Our encoder used the literal values implied by the BG notation. A value of six thirty-seconds was given to the first two dotted eighth notes, but for the third he assigned the value of five thirty-seconds. (This implies that one divides the single visual object, a dotted quarter, into two virtual objects—an eighth note tied to a thirty-second note which precedes the three written thirty-seconds.⁸ The “sound” encoding of the bass voice in which these three dotted notes occur is shown in Figure 4.



rest	8	q	
D3	1	t	d [[[
E3	1	t	d ===
F#3	1	t	d ===
G3	1	t	d ===
F#3	1	t	d ===
E3	1	t	d ===
F#3	1	t	d ===
D3	1	t	d]]]
B3	6	e.	d [
B3	2	s	d]\
A3	6	e.	d [
G3	2	s	d]\
measure 2			
F#3	6	e.	d [
G3	2	s	d]\
F#3	6	e.	d [
E3	2	s	d]\
D3	8	q	d

⁸ This is a historically founded usage which is ubiquitous in printed scores and manuscripts of nineteenth-century Germany. What it demonstrates, however, is a third-meaning for a dot.

E3	8	q	d	
measure	3			
A2	4-	e	d	[-
A2	1	t	d	=[[
E3	1	t	d	===
F#3	1	t	d	===
G3	1	t	d]]]
A3	16	h	d	
G3	8-	q	d	

Figure 4. Encoding of dotted eighth-notes in the bass voice of the D-Major Fugue from the Well-Tempered Clavier, Book I.

In Bar 1, the sixteenth-note following the dotted eighth gives a literal indication that in eight subdivisions of the (quarter-note) beat, the dotted note would occupy six sub-beats, the sixteenth two. A representation intended to produce the correction notation would have to assume this relationship. A second interpretation is allowable, however, because this movement is generally considered to be in the French-overture style and therefore to be subject to double-dotting (elongation of the dotted notes at the expense of the sixteenth). Where opinions differ is on whether *all* dotted notes throughout the piece should be treated in the same manner and on whether the over-dotting should be constrained by precisely binary increases or whether it should be freer and more variable from instance to instance. In Bar 2, matters are slightly more complicated. The dotted note in the left hand on Beat 2 spans the duration of either six or seven thirty-seconds, depending on whether double-dotting is assumed. A representation intended to produce a pedagogical edition could simply provide a double dot followed by a thirty-second, but the notation as shown here is the more widely used one.

These considerations pale in comparison to the rhythmic interpretation of the left-hand on Beat 1 of Bar 3. Here the dotted note can correspond to five, six, or seven thirty-seconds. In the *Bach Gesellschaft* edition from which we work it is usually the five-thirty-seconds interpretation that is intended by this obsolete notation, in which the dot is really a substitute for a tie to an unprinted thirty-second. Thus the three written thirty-seconds are real thirty-seconds. To reproduce this graphical presentation in commercial notation software, however, one would need to suppose the three thirty-seconds to be triplets (so as to give the dotted note its implied written value). To perform the work with double-dotting, one could also lengthen the dotted note and change the three thirty-seconds to three sixty-fourths. If one takes the view that the dotted-note equals six thirty-seconds, then the three written thirty-seconds are triplets. If one takes the view that the dot should be read as double, then the three thirty-seconds are triple sixty-fourths.

The encoder avoided treating any of the dotted notes as doubly dotted, for this decision should rest with the editor and/or performer. However, the encoder is forced to make some decisions, for although the software can store information on pitch variants, storing information for rhythmic variants is more complicated, as it may involve several notes. Machines cannot process indefinite information. Because of examples like this, the details of encoding will always pose problems in

some contexts. Careful design and good documentation should keep encoded repertoires serviceable for a long time to come.

2. Note-group and phrase-level variants

After interpretation, performance options traceable to the composer offer another area of consideration by the encoder. It may be preferable to encode for different instruments, but it will depend on the degree of difference between the two versions. Bach's keyboard transcriptions of Italian concertos for violin and string orchestra illustrate a case in which two encodings are necessary. The quantitative note-for-note differences are extremely numerous because of changes to the texture of the music. Yet in sound reproduction, the cognitive similarity of the two instantiations would be very high. Bach is not necessarily illustrative of all keyboard transcriptions of instrumental music. In our Vivaldi corpus, the four concerti from Op. 3 which were transcribed for keyboard in an English manuscript known as Anne Dawson's book offer another useful model of the need for separate encodings: the texture is simplified rather than enhanced, but the ornamentation issues from the vocabulary of English keyboard music. The octave register is altered here and there in the transcription to suit both the mechanics and the sonority of the new instrument (Figure 5).



Figure 5a. Transcription for clavichord of Vivaldi's *Violin Concerto Op. 3, No. 5, third movement*, from *Anne Dawson's Book*.



The image shows two musical staves. The top staff is for the Violino principale (Violin) and the bottom staff is for the Violoncello (Cello). Both are in 3/4 time, marked Allegro, and have a key signature of two sharps. The Violino staff shows a series of eighth-note patterns, and the Violoncello staff shows a similar pattern. Both staves end with a dynamic marking of *p* (piano).

Figures 5b and 5c. *Violino principale* and *Violoncello* from the third movement of Vivaldi's *Violin Concerto Op. 3, No. 5*.

Even in this relatively simple texture we see immediately that the transcription is not consistently a skimming off of treble and bass but instead the product of a more complex process of selection, reflecting in part the alternation between the violins in the orchestral model.

Sometimes there is no choice but to completely modernize a part. The editors of the Bach Gesellscaft did not know that the *oboe d'amore* was a transposing instrument, but it would be ludicrous to reproduce the untransposed part in a modern edition. Though we always retain the source transcription, the treatment of such incidents requires an extra pass to produce something useable today.

In Vivaldi's Violino Principale parts, a recurrent problem is that of arpeggios. Sometimes the realized arpeggio appears in the printed or manuscript original. Sometimes only a chordal is given. Sometimes a quasi polyphonic, quasi-chordal notation is present. Here most performers and analysts are accustomed to a realization. Such passages can be open to interpretation in the order of the notes. Many of the "repetitive" or "mechanical" passages mocked by Vivaldi's detractors are actually editorial realizations to which little thought was applied. Consider, for example, the passage from Vivaldi's concerto Op. 8, No. 8, shown in Figure 6.⁹

⁹ Antonio Vivaldi: The Four Seasons and Other Concertos in Full Score, Op. 8 (ed. E. Selfridge-Field), Mineola NY: Dover Publications, 1995. Our edition began with a full encoding of all twelve works in the Le Cène print of 1725 as well as all known manuscript sources from Vivaldi's time.



Figure 6. Vivaldi arpeggios from the Violino principale of Op. 8, No. 8, Allegro.

In the original print, Bars 51-75 are rendered as dotted half-note chords. There is no auditory evidence to prove that Vivaldi invariably recommended the down-down-up figuration. In many cases two possible melodic lines can be extrapolated from long series of “arpeggiation” chords. In other cases invertible figuration, or passages in which downward, upward, and mixed-direction arpeggios produce the most musical result (that is, the one most in keeping with voice-leading practices of the time).

Vivaldi can be very precise about note-groups and bowing in long passages of running sixteenth notes. When he is, the figuration is not easily reduced to a simple pattern. Consider, for example, the passage from Op. 8, No. 11 shown in Figure 7.



Figure 7. Unusual style of bowing indicated in Violino Principale of the first movement of Vivaldi's Op. 8, No. 11.

Vivaldi clearly differentiates between the open E string (shown in the original with a slash across the stem) and the stopped A string (on which many E's are also played). This passage is arguably one which at another time could have been indicated by a chordal shorthand for bariolage, although the details of execution would be entirely obscured. In the related area of *scordatura* notation, Vivaldi sources are inconsistent.

Pisendel's transcriptions of Vivaldi's instrumental music present their own idiosyncracies of bowing and other articulation indications. They occasionally give note diminutions in the violoncello part which are not found in other sources. They sometimes require separate encoding. Continuo figuration varies in curious ways between Vivaldi's autographs and prints made in Amsterdam, such that one must suppose amateur players were uppermost in the publisher's mind. Vivaldi's 6-5 indication is in some cases changed to 6-4!

3. Part-level and orchestral variants

One of the most pernicious problems in encoding, in score-and-part production, and in data translation is that of *divisi* strings. This problem owes to space-saving layouts, which often also aid the rapid visual appraisal of a score. If the violins play in unison, they may be notated on one staff. Frequently, however, the parts divide into two (or more) true parts here and there. Because Handel in particular is full of *divisi* passages of several kinds (two violins in some passages, three in others; violin with intermittent oboe, continuo with intermittent cello or bassoon), we have been prompted to work with several varieties of this problem. Not all problems related to Handel's *divisi* can be solved by encoding ploys. Handel was quite careless about indicating the components of the starting ensemble. Cues saying "senza oboi" is common in contexts where no oboe has previously been

mentioned. Determining whether it has been present from an opening ritornello or was called in at the last change of meter or texture can require arbitrary judgment.

Vivaldi introduces a slightly different range of alternating and combined instruments. In many of his manuscripts, a series of empty staves sits above a fundamental bass and the words “con li bassi” are sprinkled here and there. What this means is that the bass gives the basic outline of the music, which may be mimicked at higher octaves in the violin and, if present, viola parts. In such cases, the manuscript is not a complete score. The likely realization of the string parts is obvious at a general level, but in concerto textures the nature of the accompaniment may be subject to interpretation. In fully written scores, slow movements commonly omit continuo and sometimes cello as well so the process may work in the opposite direction. In fully written scores it is also common to find more activity (that is, more notes) in an obbligato cello part than in a perfunctory continuo line. How much latitude may be taken in an encoding of such a work?

Our general approach to the encoding of *divisi* parts now favors keeping the encodings for each individual instrument in a separate file and providing an additional file in which two or more instruments are combined. This has the advantage that when parts need to be differentiated on one staff by stem direction, there is recourse to a composite view. The composite will not serve for sound output, if the timbres are different. For this the single-instrument files can be used.

Pisendel’s transcriptions of some of the concertos in Vivaldi’s Op. 8 (preserved in the Sächsische Landesbibliothek, Dresden) have independent refinements of bowing and other articulation. They also have added rhythmic diminutions here and there, especially in the cello. Continuo figuration sometimes varies between Vivaldi’s autographs and prints from Amsterdam, where it appears that in the interest of serving the amateur performers of the time, Vivaldi’s pungent 6-5’s were sometimes changed to 6-4’s!

Differences which subsist only the substitution of one instrument for another are generally easy to handle and may not require separate encoding, but for the timbral requirements of sound output. The Vivaldi repertory is rife with truly alternative versions of concertos (violin or oboe, violin or bassoon, et al). Most suggest adaptation to changed circumstances, which sometimes implies differences in the skill of the intended soloist(s). These circumstances require close inspection of the alternatives in order to determine whether the versions differ other than by the instrumental label applied at the start of each movement.

4. Tree-structure variants

Any thought of encoding variants in a single set of files evaporates in the face of tree-structure variants. Tree-structure variants result from a change in the composer’s thinking or an

adaptation to changed circumstances. In the third movement of Vivaldi’s violin concerto Op. 8, No. 11, five different readings are supported by one manuscript source (Vivaldi’s autograph, in Turin). They particularly affect the content of the solo episodes but they somewhat affect ritornellos downstream of these solos. A map of the movement’s overall plan is shown in Figure 8.

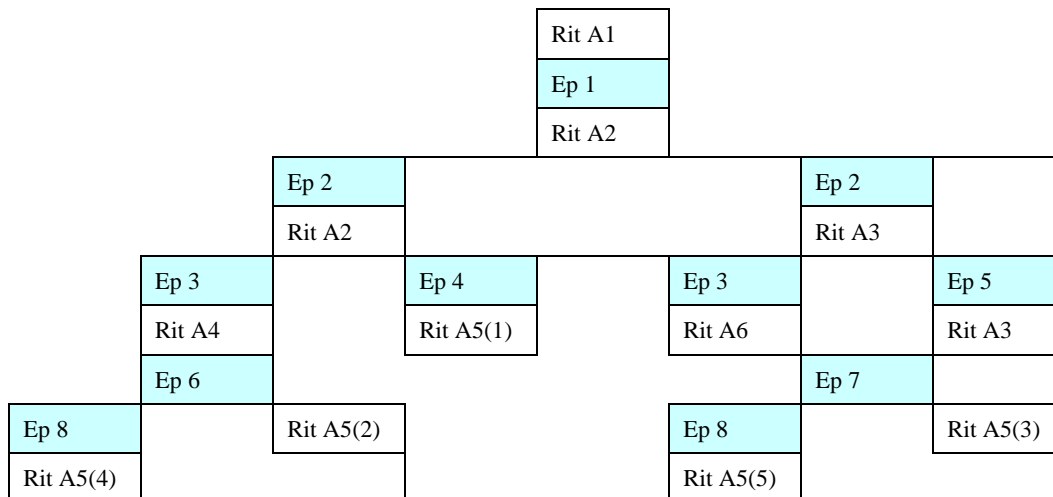

Paths:

Rit A1, Ep 1, Rit A2, Ep 2, Rit A2, Ep 3, Rit A4, Ep 6, Ep 8, Rit A5(4).	148 bars
Rit A1, Ep 1, Rit A2, Ep 2, Rit A2, Ep 4, Rit A4, Ep 6, Rit 5(2).	163 bars
Rit A1, Ep 1, Rit A2, Ep 2, Rit A2, Ep 4, Rit A5(1).	205 bars
Rit A1, Ep 1, Rit A2, Ep 2, Rit A3, Ep 3, Rit A6, Ep 7, Ep 8, Rit A5(3).	197 bars
Rit A1, Ep 1, Rit A2, Ep 2, Rit A3, Ep 5, Rit A3, Ep 7, Rit A5(5).	201 bars

Figure 8. Possible paths through the third movement of Vivaldi’s manuscript of the violin concerto Op. 8, No. 11, diagrammed as a tree structure. (The chart is oversimplified, as several more branches and incisions are possible. Episodes are highlighted.)

The versions vary in length. Four of them end with Ritornello (“Rit”) A4, and one with the abbreviated A5. The episodes (“Ep”) diverge on their third appearance. The schema shown in Fig. 11 is a simplification that ignores minor differences. Effectively all these versions were “encoded” (that is, notated) in one file. The result is chaos. It is not an isolated case in the Vivaldi repertory. In Op. 8 two other works (No. 7 and No. 9) have movements with similar (but simpler) problems.

A very different result from changing circumstances is represented by the progressive reworkings of the aria “How beautiful are the feet” in Part Two of Handel’s *Messiah*. In encoding this work (1987) we surveyed the variant material linked to its nine earliest performances (1742-1759). Five settings of this aria emerged. They vary by key, instrumentation, voicing, texture, and structure. In the first instance (1), the aria is set in G Minor for soprano, two violins, and continuo. It is through-

composed. In the second case (2), it begins in the same way but takes on a da capo structure. The B section consists of SATB chorus and an orchestra of two violins, two oboes, viola, and basso continuo. The key remains the same. The third version (3) is again da capo, but the movement has been transposed to C Minor. A contralto sings the solo in the A Section, a tenor in the B section. The A section calls for unison violins; the B section is accompanied by continuo only. In the fourth and fifth versions (4, 5), the movement is set throughout for chorus (SATB in 4, SAATB in 5) and orchestra. It is in D Minor. Soprano and alto solos set an octave apart in Version 4 are changed to solos for alternating altos in Version 5, where they sing at the same pitch, as though in canon. The opening bars of the first version are shown in Figure 9.

Larghetto

The musical score shows the beginning of the piece. It is in 12/8 time and D minor. The tempo is marked 'Larghetto'. The instruments are Violino I, Violino II, Soprano, and Bassi. The Soprano part has a rest for the first few measures, then enters with the lyrics: 'How beau-ti-ful are the feet of them that preach the gos-pel of peace—, how'. The music is marked with a piano 'p' dynamic.

Figure 9. "How beautiful are the feet" from Part Two of Handel's *Messiah* in the original version (1742).

What identifies the versions are all holding the same position and providing the same function on the overall structure of the oratorio is, of course, the text. It is unvarying. In a digital environment, there is no escape from five encodings to capture all these possible settings.

Conclusions

What makes digital frameworks desirable is that they enable multiple resolutions to the problems that arise from the kinds of differences discussed here. Although pioneers in the encoding of musical scores were optimistic that the computer would soon provide an apparatus for source filiation, that possibility only exists after all the sources have been encoded. For some repertoires survived by myriad sources of questionable value, the effort involved does not justify the result. Sometimes the informed eye is the better tool.

New possibilities are opening for variants differentiated more by the range of notation styles in which they are preserved than by music content. The pioneer in exploring its corollary—flexible output schemes reflecting different ideas of musical interpretation—is Theodor Dumitrescu, though his *Corpus Mensurabilis Musicarum Electronicarum* (CMME). A user may elect to view a particular piece with *Mensurstriche* or conventional barring, while meanwhile the encoding of manuscripts of Renaissance music proceeds apace. What is ultimately important about digital editions is their malleability—the possibilities for fashioning new readings, for demonstrating new interpretations, and for presenting the material from new perspectives.

At the present time the gap between data used in music publishing (which is hard-wired for a specific task and style but is hypothetically useable towards other ends) and data made freely available by academically-based collections, such as *MuseData*, *KernScores*, and CMME, to those with diverse special purposes is peculiarly wide. There are no technical impediments to the pooling of much larger collections of data, to which questions of musical content and style could be addressed with the expectation of revelations impossible by analog means. The obstacles are entirely administrative.